

# U.S. DEPARTMENT OF TRANSPORTATION FEDERAL HIGHWAY ADMINISTRATION

REG	STATE	PROJECT	SHEET NO.	TOTAL SHEETS
N/A	CA	FLAP SR 36(13) STATE ROUTE 36	A1	A8

User: kelly.terrell

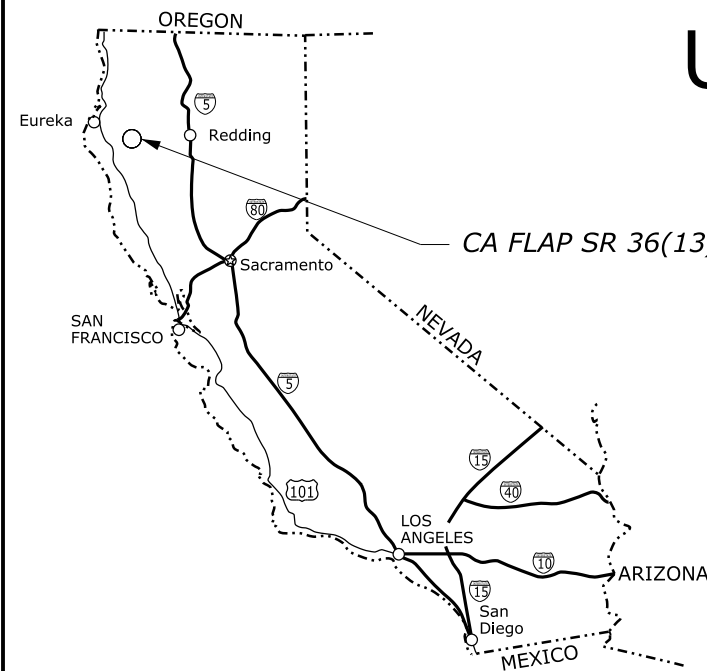

### KEY MAP OF CALIFORNIA

**TYPE OF CONSTRUCTION:**  
Road reconstruction, grading,  
drainage, aggregate base,  
asphalt surfacing and  
retaining walls

**DESIGN DESIGNATIONS:**  
ADT (2015) ----- 1090  
ADT (2035) ----- 1300  
DHV ----- 145  
D ----- 60%  
T ----- 6%  
V ----- 55 mph  
e(max) ----- 8%

**U.S. CUSTOMARY DIMENSIONS:**  
Slopes are expressed as RISE:RUN

**SPECIFICATIONS:**  
"STANDARD SPECIFICATIONS FOR CONSTRUCTION OF ROADS  
AND BRIDGES ON FEDERAL HIGHWAY PROJECTS, FP-03,  
U.S. CUSTOMARY UNITS"

**BOUNDARY DISCLAIMER:**  
Boundary lines shown on this plan set are approximate.  
They do not constitute a complete boundary survey of  
properties and ownership. Existing property lines and  
easement shown are based on field measurements  
and descriptions in documents of record.

**PRELIMINARY 95%  
FEBRUARY 2015  
NOT FOR CONSTRUCTION**



Know what's below.  
Call before you dig.  
www.call811.com

**END PROJECT  
CA FLAP SR 36(13)  
2108+99.97  
HUM MP 40.44**

**BEGIN PROJECT  
CA FLAP SR 36(13)  
1903+00.00  
HUM MP 36.05**

## PLANS FOR PROPOSED CA FLAP SR 36(13) **STATE ROUTE 36** HUMBOLDT COUNTY LENGTH 3.9 MILES

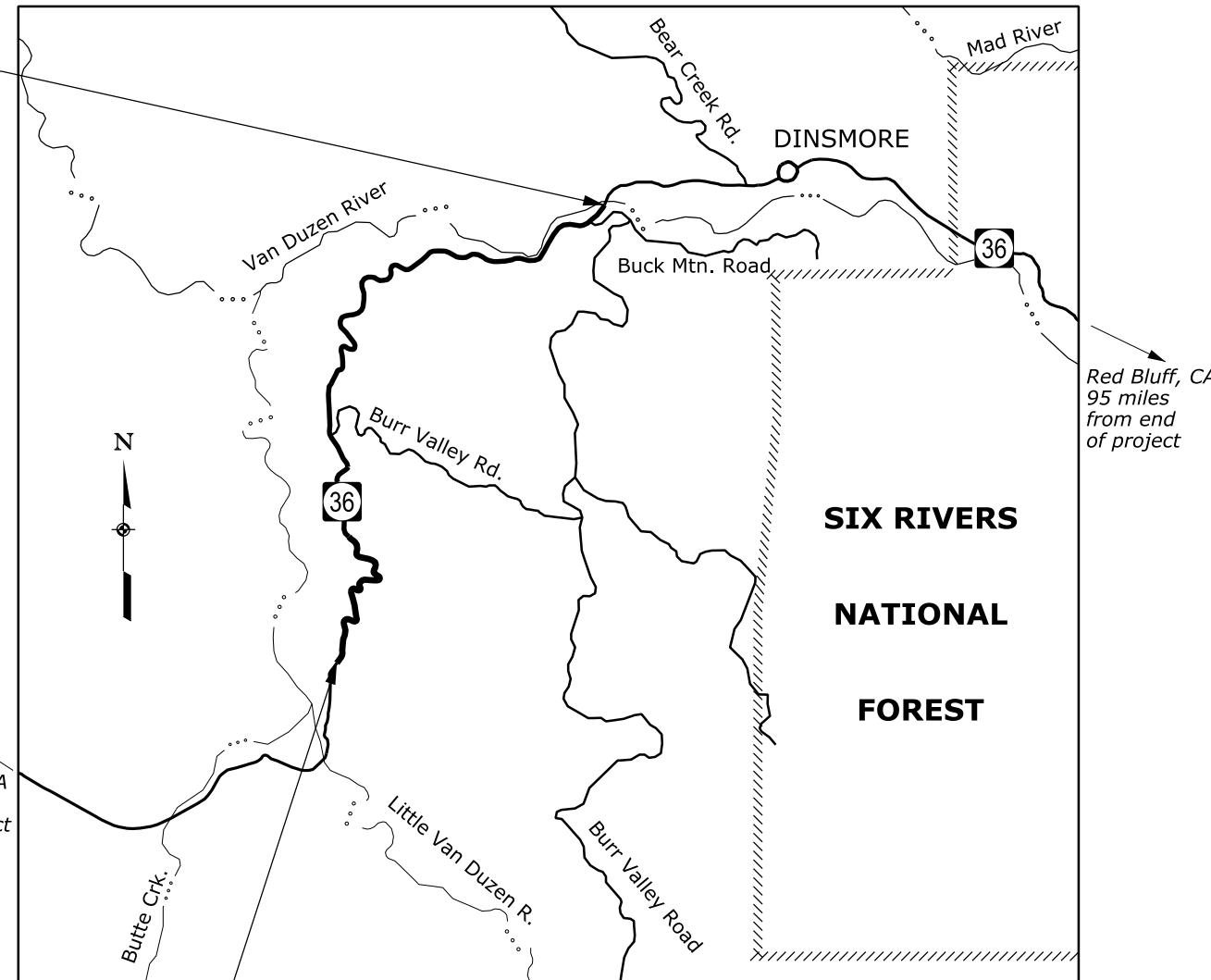

INDEX TO SHEETS	
SHEET	DESCRIPTION
A1	TITLE SHEET
A2 - A3	CONVENTIONAL PLAN SYMBOLS & ABBREVIATIONS
A4	SURVEY CONTROL
A5 - A6	SITE MAPS
A7	TYPICAL SECTION MAINLINE
A8	TYPICAL SECTIONS APPROACH ROADS AND PULLOUTS
B1 - B3	SUMMARY OF QUANTITIES
B4	GRADING SUMMARY
B5	SURFACING SUMMARY
B6 - B11	DRAINAGE SUMMARY
B12 - B16	REMOVALS SUMMARY
B17 - B22	MISCELLANEOUS SUMMARY
C1-C15	MAINLINE PLAN AND PROFILE
D1 - D10	APPROACH ROAD PLAN AND PROFILE
E1 - E30	EROSION AND SEDIMENT CONTROL PLAN
E31	C157-50 SILT FENCE
E32 - E33	C157-51 TEMPORARY INLET PROTECTION
E34	C157-57 SLOPE DRAIN
E35	157-A SEDIMENT TRAP
E36	157-B CHECK DAM
E37	157-C SEDIMENT WATTLE
E38	157-D STABILIZED CONSTRUCTION ENTRANCE
F1	204-A FURROW DITCH
F2	204-B EMBANKMENT BENCHING
F3 - F4	207-A REINFORCED SOIL SLOPE
F5	207-B DEEP PATCH
G1	C251-50 PLACED RIPRAP AT CULVERT OUTLETS
G2	251-A RIPRAP RUNDOWN
G3	251-B SHOULDER STABILIZATION
G4	252-A ROCK BUTTRESS
G5 - G8	MSE WALL LAYOUTS
G9	C255-50 MECHANICALLY STABILIZED EARTH WALL
G10	C255-51 MSE WALL DRAINAGE
G11 - G12	SOIL NAIL WALL LAYOUTS
G13	259-A SOIL NAIL WALL
S1	CMP PLAN AND PROFILE BURR CREEK 1968+81
S2	BOX CULVERT PLAN AND PROFILE 2014+36
S3 - S10	500-A STANDARD REINFORCED CONCRETE BRIDGE BOX AND SLAB TYPE
<b>CONTINUED ON NEXT SHEET</b>	

PLANS PREPARED BY  
  
U.S. DEPARTMENT OF TRANSPORTATION  
FEDERAL HIGHWAY ADMINISTRATION  
CENTRAL FEDERAL LANDS HIGHWAY DIVISION  
DENVER, COLORADO

APPROVED: \_\_\_\_\_ DATE: \_\_\_\_\_  
DIRECTOR, PROJECT DELIVERY  
CENTRAL FEDERAL LANDS HIGHWAY DIVISION

10:58:00 AM N:\CA\sr36(13)\Roadway\CADD\_Sheets\A-Gen\_sht\A01\_tti.dgn 2/4/2015

PROJECT MANAGER J. HERLYCK	LEAD DESIGNER K. TERRELL-PROSE
-------------------------------	-----------------------------------

ABBREVIATIONS

Table of abbreviations including symbols like centerline, abutment, average daily traffic, aggregate, ahead, alternate, approach, asphalt, both faces, beginning, back, bench mark, balance point, bridge, bearing, concrete box culvert, center to center, clear, corrugated metal pipe, county, column, concrete, construction, construction joint, continuous, corrugated, creek, point of curve to spiral, centers, contingent sum, culvert, decrement, design hour volume, drop inlet, diameter, diagonal, diaphragm, distance, district, donation land claim, drawing(s), east, superelevation rate, elevation with number, elevation, embankment, Engineer(s), edge of pavement, equation, edge of road, and others.

Table of abbreviations including symbols like length of curve, lamination, latitude, longitudinal, lump sum, left, low water, magnetic, maintenance, material, maximum, minimum, monument, mountain(s), north, normal crown, negative, number, on centers, other face, outside diameter, point of curve, point of compound curve, perforate, point of intersection, plate, point on curve, point on spiral, point on tangent, project, pounds per square inch, pavement, quantities, radius, range, right-of-way, road, roadway, reconstruction, reinforcement, required, reservoir, Reservation, retaining wall, reference hub, right, route, south, seasonal average daily traffic, point of spiral to curve, section, shoulder, spacing, Spaces or Spaced, specification, street, point of spiral to tangent, standard, stiffener, straight, structural, symmetrical, tangent length, township, tangent, temporary bench mark, temporary construction easement, transverse, point of tangent to spiral, typical, design speed, vertical, vehicles per hour, vertical point of intersection, west.

DRAINAGE SYMBOLS

Ditch (Existing, Proposed)

Flow Arrow

Drainage or Small Creek

Lake, Pond or Reservoir

Large Creek

Wetland

River

Spring

Bridge (Existing, Proposed)

Box Culvert (Existing, Proposed)

Pipe Culvert (Existing, Proposed)

With End Sections (Existing, Proposed)

With Headwalls (Existing, Proposed)

With Drop Inlet (Existing, Proposed)

Underdrain (Existing, Proposed)

Riprap Apron (Proposed)

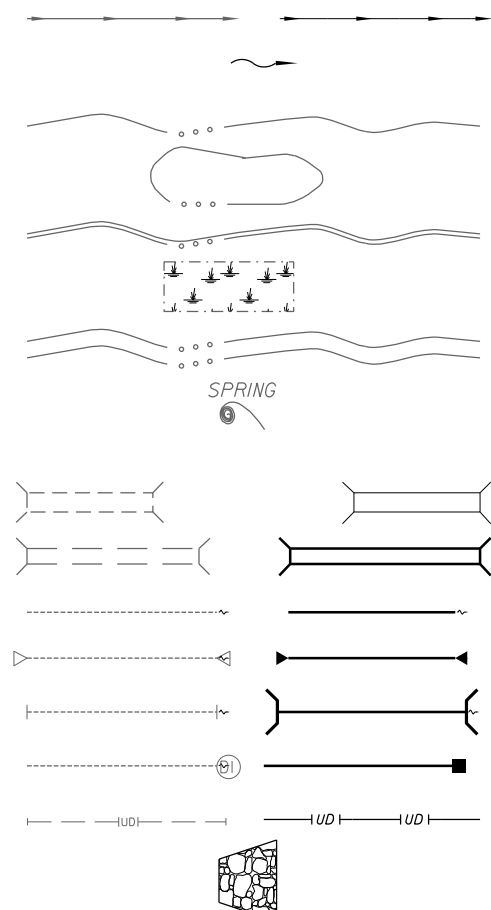

EROSION & SEDIMENT CONTROL SYMBOLS

Bonded Fiber Matrix Mulching

Check Dam

Diversion Berm

Erosion Control Mat

Riprap

Sediment Log

Silt Fence

Stabilized Construction Entrance

Temporary Inlet Protection

Wattle

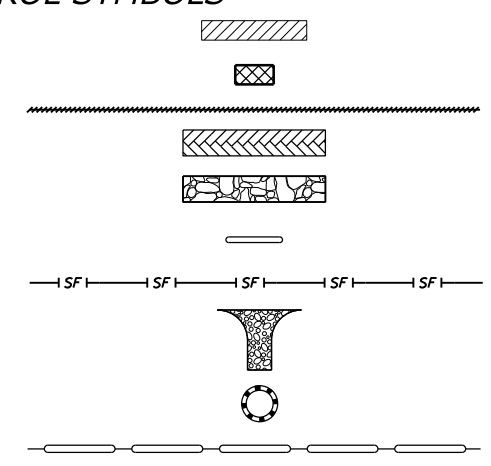

FENCE & CATTLEGUARD SYMBOLS

Fence (Existing, Proposed)

Fence w/ Gate (Existing, Proposed)

Cattleguard (Existing, Proposed)

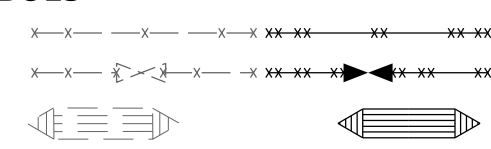

GEOLOGIC SYMBOLS

Boring Location (Existing, Proposed)

Material Source



Table with columns: REG, STATE, PROJECT, SHEET NO., TOTAL SHEETS. Values: N/A, CA, FLAP SR 36(13) STATE ROUTE 36, A2, A8.

INDEX TO SHEETS (CONTINUED)

Table with columns: SHEET, DESCRIPTION. Lists sheets T1 through T29, U1 through U25, and V1 through V14 with their respective descriptions.

SEPARATE COVER CROSS-SECTIONS

U.S. DEPARTMENT OF TRANSPORTATION FEDERAL HIGHWAY ADMINISTRATION CENTRAL FEDERAL LANDS HIGHWAY DIVISION

CONVENTIONAL PLAN SYMBOLS AND ABBREVIATIONS

3:09:19 PM N:\CA\sr36(13)\Roadway\A-Gen\_Sht\A02\_A03 sym.dgn 10/1/2014

### LANDSCAPING & VEGETATION SYMBOLS

Tree 

Treeline 

**MAPPING SYMBOLS**

Building (Existing, Proposed) 

Coordinate Grid Tick 

North Arrow 

Railroad

Single Track 

Double Track 

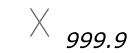
Spot Elevation 

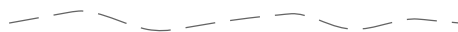
Trail 

Survey Control Point 

### RIGHT-OF-WAY SYMBOLS

**Boundaries**

National 

State 

County 

City 

Township or Range Line 

Section

1/4 Section 

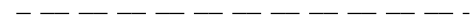
1/16 Section 

Bureau of Indian Affairs 

Bureau of Land Management 

National Forest 

National Park 

National Wildlife Refuge 

**Easements**

Permanent (Existing) 

Permanent (Proposed) 

Temporary (Proposed) 

Monument (As described) 

Parcel Number 

Property Line 

Right-of-Way Line (Existing) 

Right-of-Way Line (Proposed) 

Section Corner (Found, Projected) 

1/4 Section Corner (Found, Projected) 

1/16 Section Corner (Found) 

### GUARDRAIL, BARRIER & WALL SYMBOLS

Guardrail (Existing, Proposed) 

Guardwall (Existing, Proposed) 

Median & Side Barrier (Existing, Proposed) 

Retaining Wall (Existing, Proposed) 

### ROADWAY SYMBOLS

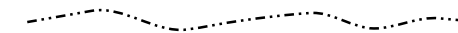
Clearing/Construction Limits 

Slope Stake Limits

Top of Cut 

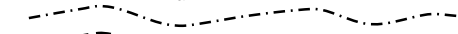
Transition 

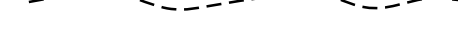
Toe of Fill 

Edge of Roadway

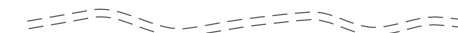
Existing 

Proposed 

Roadway Centerline (With Station ticks) 

Roadway Obliteration 

### SIGN SYMBOLS

**Signs**

Commercial (Existing, Proposed) 

Delineator (Existing, Proposed) 

Portable (Proposed) 

Post Mounted (Existing, Proposed) 

### UTILITY SYMBOLS

**Irrigation Ditch**

Underground (Existing, Proposed) 

Surface (Existing, Proposed) 

Support Pole (Existing, Proposed) 

Support Pole Anchor (Existing, Proposed) 

Street Light (Existing, Proposed) 

Telephone Booth (Existing, Proposed) 

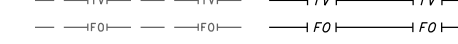
Telephone Pedestal (Existing, Proposed) 

**Underground Utility (Existing, Proposed)**

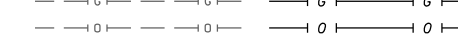
CATV 

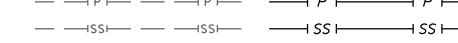
Fiber Optic 

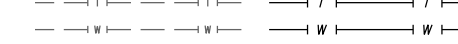
Gas 

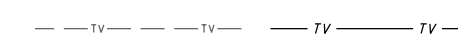
Oil 

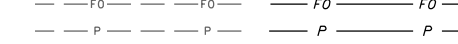
Power 

Sanitary Sewer 

Telephone 

Water 

**Overhead Utility Line (Existing, Proposed)**

CATV 

Fiber Optic 

Power 

Telephone 

### MISCELLANEOUS SYMBOLS

See Note 4 

### PROJECT SPECIFIC SYMBOLS

REG	STATE	PROJECT	SHEET NO.	TOTAL SHEETS
N/A	CA	FLAP SR 36(13) STATE ROUTE 36	A3	A8

Superelevation Diagram 

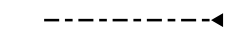
Pipe Downdrain 

Paved Ditch 

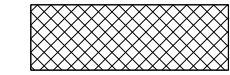
Special Rock Embankment 

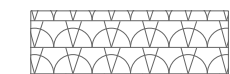
Riparian Area 

U.S. DEPARTMENT OF TRANSPORTATION  
FEDERAL HIGHWAY ADMINISTRATION  
CENTRAL FEDERAL LANDS HIGHWAY DIVISION

**CONVENTIONAL PLAN SYMBOLS AND ABBREVIATIONS**

Sheet 2 of 2

\_User: kelly.terrell\_

3:06:40 PM N:\CA\sr36(13)\Roadway\CADD\_Sheets\A-Gen\_sht\A04\_Control.dgn 10/1/2014

PROJECT : CA 04-1(13) - Van Duzen/Peanut  
DATE OF FIELD WORK : 2012  
DATE OF FINAL ADJUSTMENT : 2012

See FP03, Section 152.02 & 107.02

REG	STATE	PROJECT	SHEET NO.	TOTAL SHEETS
N/A	CA	FLAP SR 36(13) STATE ROUTE 36	A4	A8

Paneled Points

PROJECT UNITS : US SURVEY FOOT  
COORDINATE SYSTEM : LAMBERT NAD83; CA ZONE 1 0401  
EPOCH DATE : 2010 FROM OPUS SOLUTIONS  
VERTICAL DATUM : NAVD88 Geoid12A Modeled  
Held OPUS Orthometric Hights for points 1001 & 1002

GPX FILE DATED:

Seg1

POINT NUMBER	STATE PLANE COORDINATES			GEO COORDINATES			MAPPING ANGLE	COMBINED FACTOR	JOB261.GPX STATIONS	Seg1 OFFSET	DESCRIPTION
	NORTH	EAST	ELEVATION	LATITUDE	LONGITUDE	ELLIPSOID HEIGHT					
1007	2055748.29	6102039.37	2875.97	40°27'41.52658"N	123°39'07.13573"W	2780.64553	-1°04'49"	0.99978284	1939+85.29	-137.9	CALTRANS HUMBOLT COUNTY
2006	2055640.40	6102254.06	2861.36	40°27'40.50053"N	123°39'04.33217"W	2766.04403	-1°04'47"	0.99978357	1938+05.39	-39.0	FHWA ALUMINUM CAP

PROJECT AVERAGES = 0.99988876

Seg2

POINT NUMBER	STATE PLANE COORDINATES			GEO COORDINATES			MAPPING ANGLE	COMBINED FACTOR	JOB261.GPX STATION	Seg2 OFFSET	DESCRIPTION
	NORTH	EAST	ELEVATION	LATITUDE	LONGITUDE	ELLIPSOID HEIGHT					
1008	2059563.28	6101299.43	2716.39	40°28'19.08306"N	123°39'17.63970"W	2621.07	-1°04'56"	0.99978931	1982+16.87	-26.0	CADOT ALUMINUM CAP MP37
1011	2064546.76	6104330.42	2541.11	40°29'08.88680"N	123°38'39.63491"W	2446.09	-1°04'31"	0.99979618	2052+13.42	32.2	HUM COUNTY HIWAY
2010	2064186.68	6103607.67	2545.64	40°29'05.19492"N	123°38'48.90018"W	2450.56	-1°04'37"	0.99979608	2044+07.67	23.0	FHWA ALUMINUM CAP

PROJECT AVERAGES = 0.99988876

NOTE: TO PRECISELY CHECK DISTANCES BETWEEN POINTS AS MEASURED ON THE GROUND :  
INVERSE THE STATE PLANE COORDINATES AND DIVIDE THE COMPUTED DISTANCE  
BY A MEAN COMBINED FACTOR OF THE TWO POINTS.

TO COMPUTE GEODETIC AZIMUTHS USE THE FOLLOWING FORMULA :  
GEODETIC AZIMUTH = GRID AZIMUTH + MAPPING ANGLE

6			
5			
4			
3			
2			
1	Created	8/25/14	klw
NO.	DESCRIPTION REVISIONS (OR CHANGE NOTICES)	DATE	INIT.

U.S. DEPARTMENT OF TRANSPORTATION  
FEDERAL HIGHWAY ADMINISTRATION  
CENTRAL FEDERAL LANDS HIGHWAY DIVISION

**SURVEY CONTROL**

REG	STATE	PROJECT	SHEET NO.	TOTAL SHEETS
N/A	CA	FLAP SR 36(13) STATE ROUTE 36	A5	A8

**1903+00.00  
HUM MP 36.05  
BEGIN PROJECT  
CA FLAP SR 36(13)**

**2108+99.97  
HUM MP 40.44  
END PROJECT  
CA FLAP SR 36(13)**

Bridgeville, CA  
11 miles

Dinsmore, CA

Red Bluff, CA  
94 miles

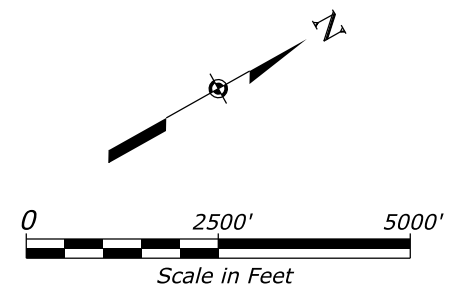

**SIX RIVERS NATIONAL FOREST**

U.S. DEPARTMENT OF TRANSPORTATION  
FEDERAL HIGHWAY ADMINISTRATION  
CENTRAL FEDERAL LANDS HIGHWAY DIVISION

**SITE MAP**

Sheet 1 of 2

\_User: thomas.mcrary\_

3:46:12 PM N:\CA\sr36(13)\Roadway\CADD\_Sheets\A-Gen\_sht\A05\_A06 site map.dgn

10/15/2014

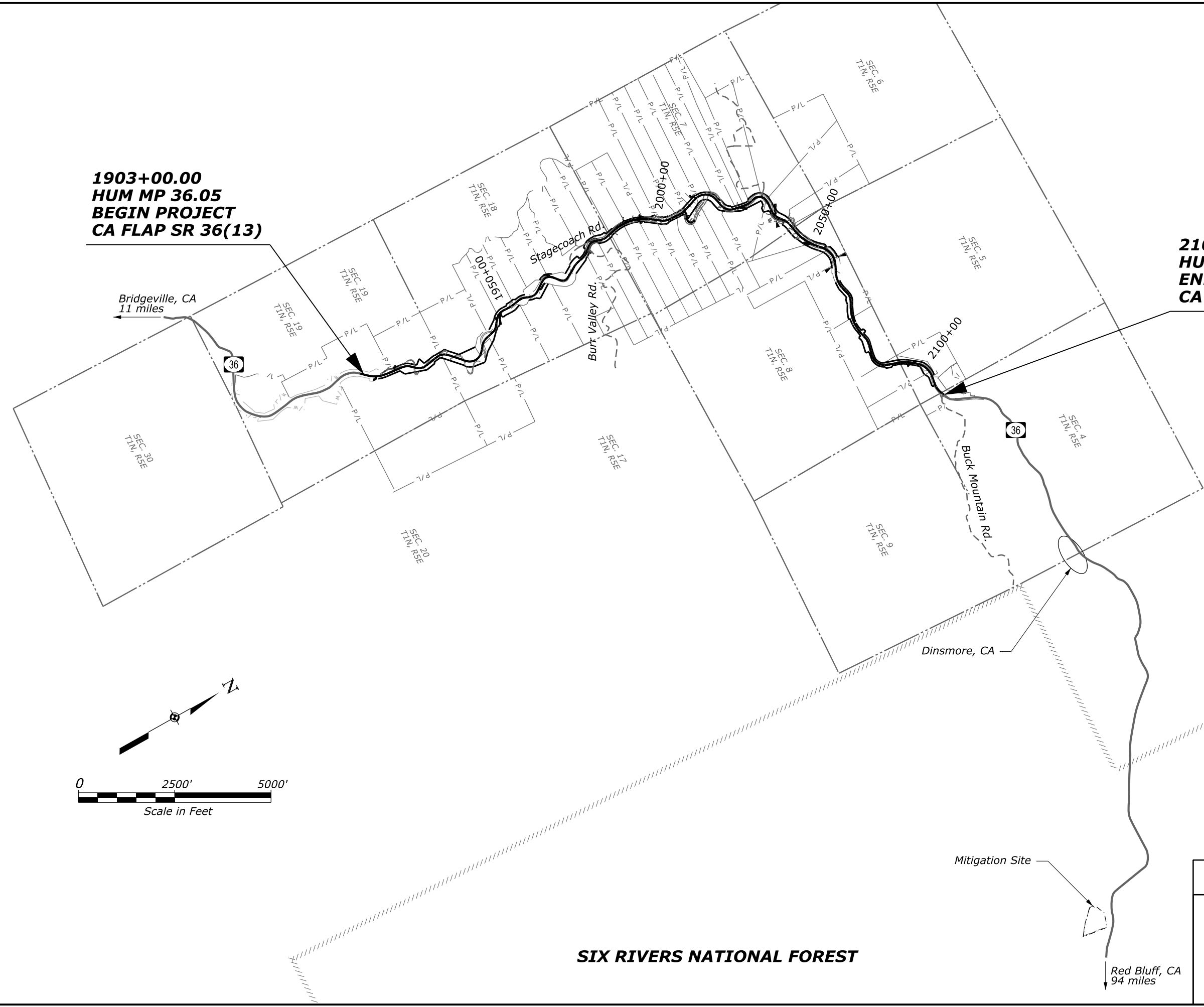

REG	STATE	PROJECT	SHEET NO.	TOTAL SHEETS
N/A	CA	FLAP SR 36(13) STATE ROUTE 36	A6	A8

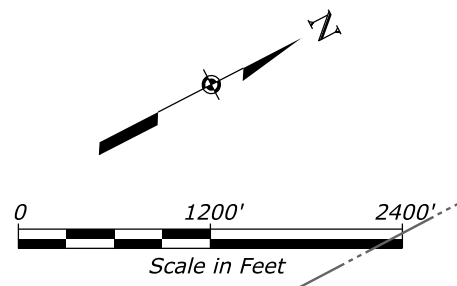

10/15/2014 4:42:05 PM N:\CA\sr36(13)\Roadway\CADD\_Sheets\A-Gen\_sht\A05\_A06 site map.dgn User: thomas.mccrory

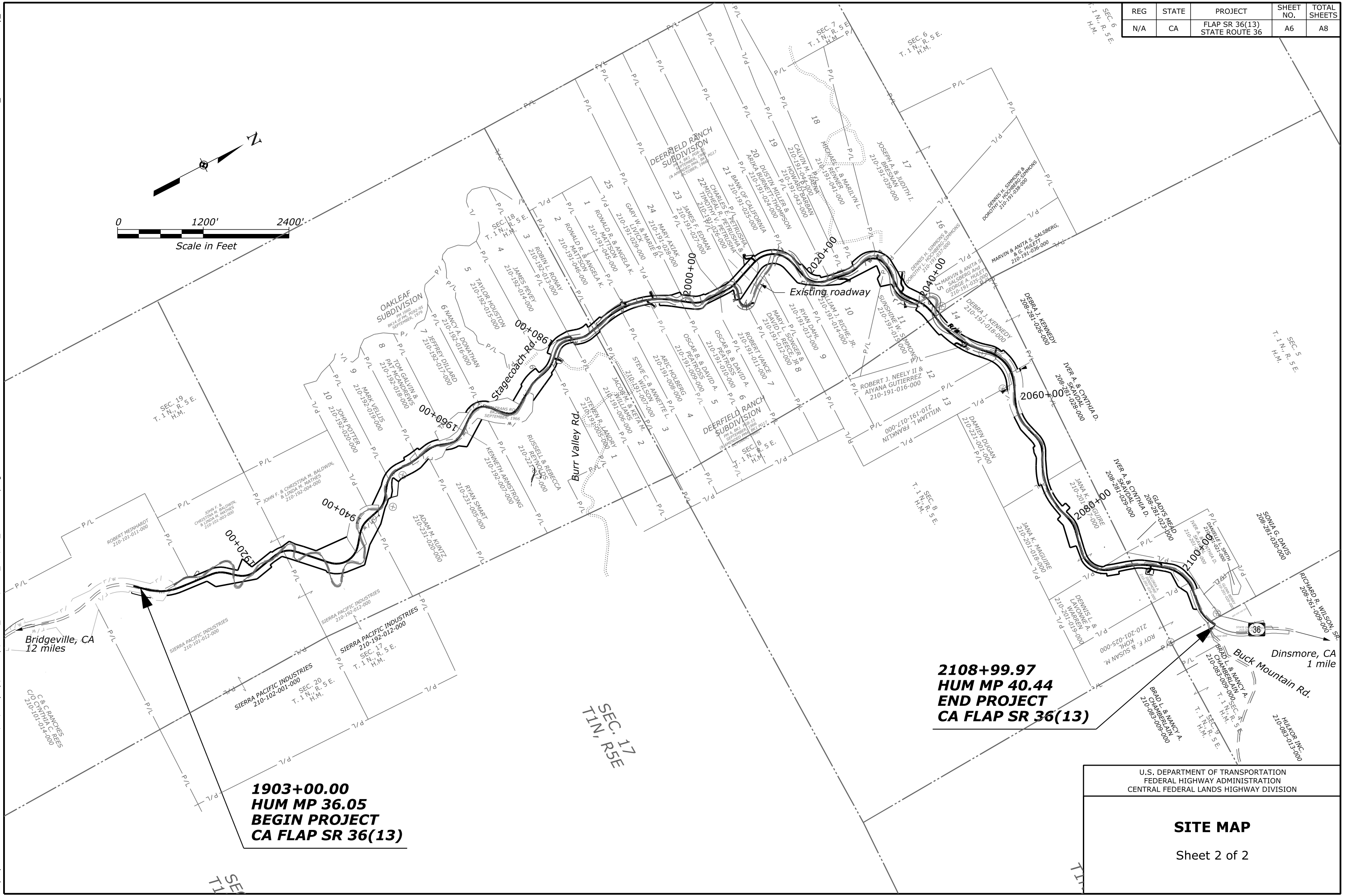

**1903+00.00**  
**HUM MP 36.05**  
**BEGIN PROJECT**  
**CA FLAP SR 36(13)**

**2108+99.97**  
**HUM MP 40.44**  
**END PROJECT**  
**CA FLAP SR 36(13)**

U.S. DEPARTMENT OF TRANSPORTATION  
 FEDERAL HIGHWAY ADMINISTRATION  
 CENTRAL FEDERAL LANDS HIGHWAY DIVISION

**SITE MAP**

Sheet 2 of 2

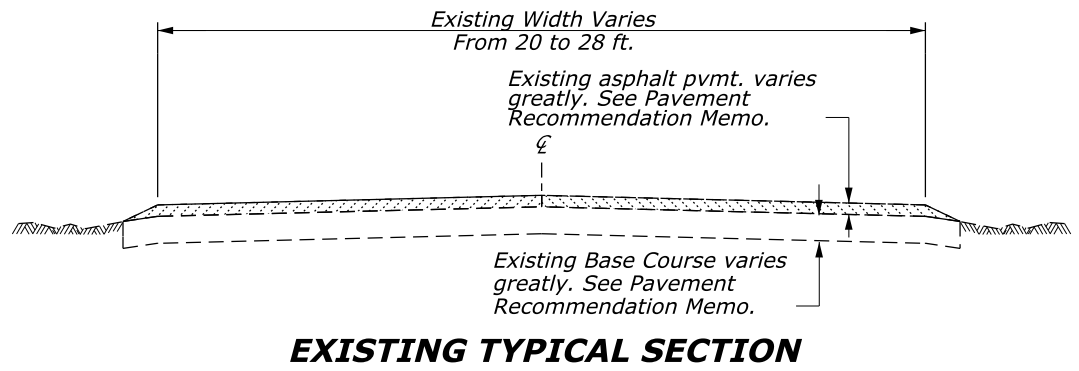

**Curve Widening<sup>⑥</sup>**

Curve Radii (ft)	Widening (ft)
400+	None
350-399	2
250-349	3
150-249	4
50-149	5

- NOTE:**
- The gradient and width of roadway ditches and the excavation and embankment slope ratios may be adjusted by the CO to assure adequate drainage and stability.
  - See the cross sections for cut and fill slope ratios.
  - Round all earth slopes and all rippable rock slopes. For cut heights less than B, reduce the B and F dimensions to the actual cut height.
  - Place asphalt concrete pavement in a minimum of three lifts. Apply tack coat between lifts.
  - Make all sign and object supports in the clear zone are crashworthy.
  - Construct curve widening as shown in the table. Apply the widening on the inside of the curves. Transition the curve widening to coincide with the length of the spiral.

**Table A - Length of Project**

Station to Station	Roadway length
1903+00.00 to 2108+99.97	20,599.97
TOTALS (ft)	20,599.97
TOTAL (mi)	3.9

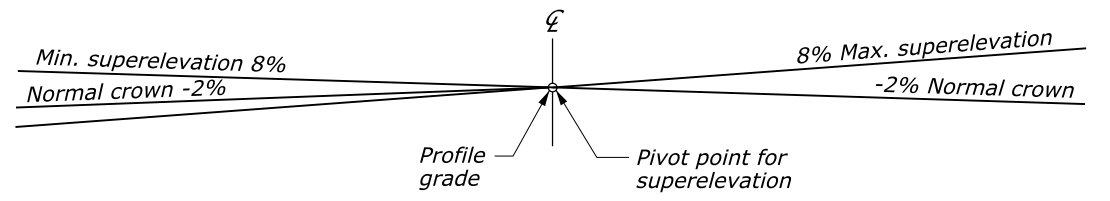
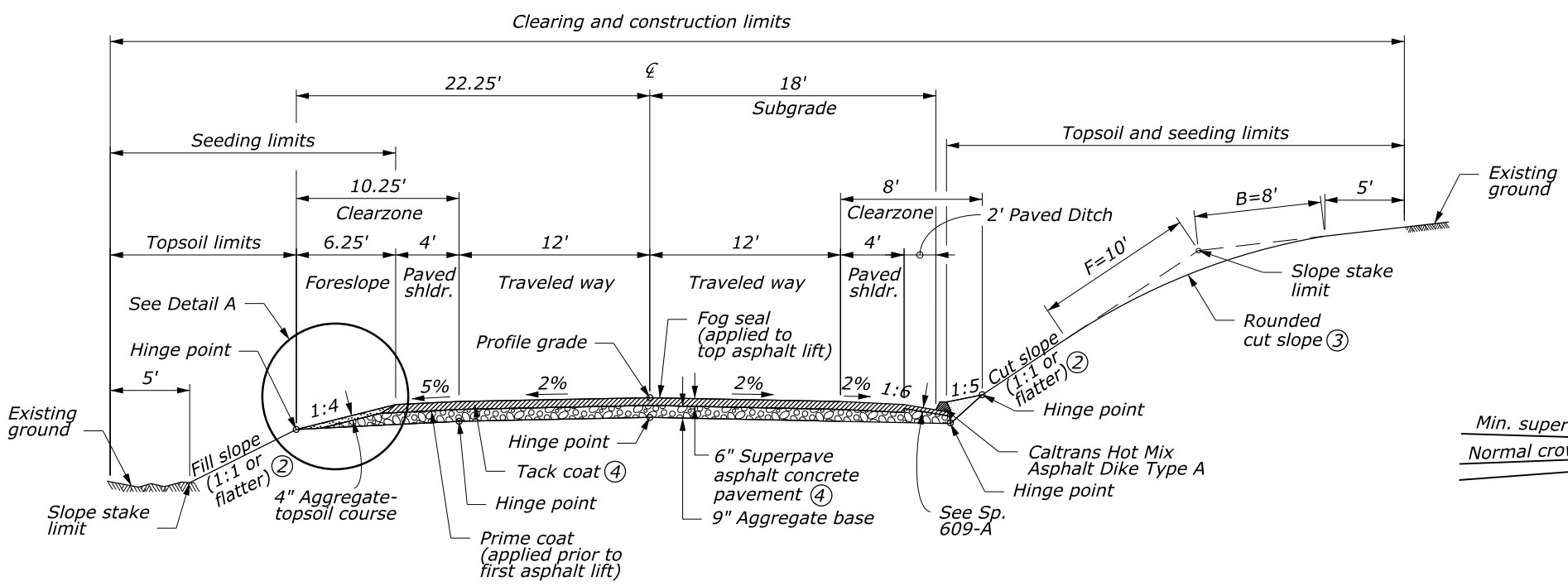

**METHOD OF SUPERELEVATION ON CURVES**  
See plans for locations of curves and superelevations

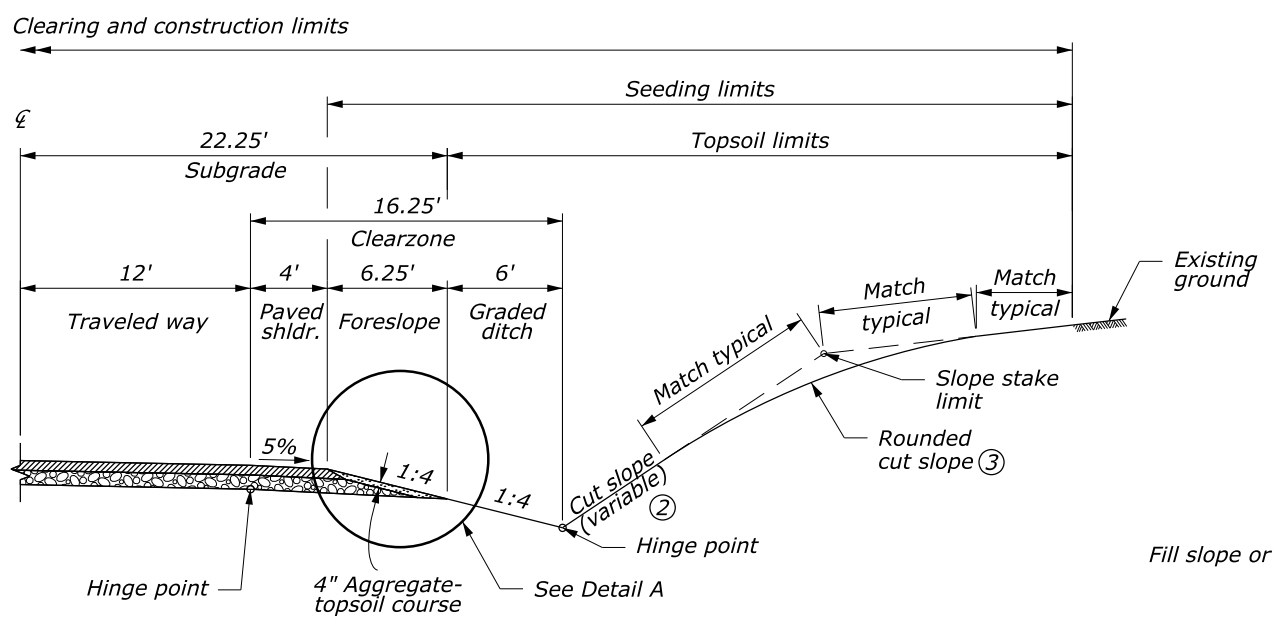

**GRADED DITCH TYPICAL SECTION**

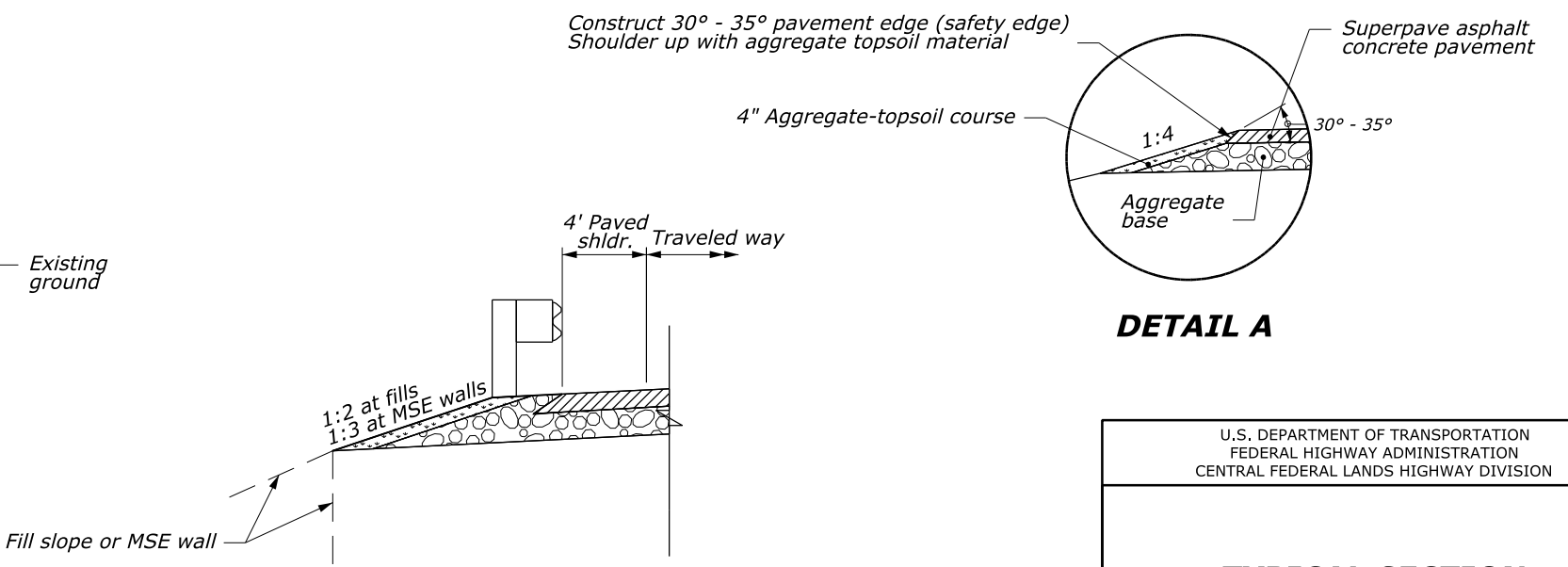

**GUARDRAIL TYPICAL SECTION**

**DETAIL A**

U.S. DEPARTMENT OF TRANSPORTATION  
FEDERAL HIGHWAY ADMINISTRATION  
CENTRAL FEDERAL LANDS HIGHWAY DIVISION

**TYPICAL SECTION MAINLINE**

NO SCALE

User: kelly.terrell\_ 4:12:03 PM N:\CA\sr36(13)\Roadway\CADD\_Sheets\A-Gen\_sht\A07 4R\_typ.dgn 1/15/2015

**NOTE:**

- Stations shown are approximate locations. Actual locations to be field verified.
- See the approach road cross-sections for cut and fill slope ratios.
- Under special conditions, the approach road angle shown may be varied  $\pm 20^\circ$ .
- Place culverts at the end of the approach road radius to provide a flatter foreslope and increased mainline recovery area.
- See the approach road cross-sections for cross slope values.
- Refer to mainline typical sections for structural section thicknesses and foreslopes.
- Construct approach roads with landing areas having grades within  $\pm 2\%$ . In snowy regions restrict this to a 0% to -2% grade. Under special conditions, use 6% maximum.
- Vary radii to fit unusual field conditions. Do not reduce existing radii or widths.  $R_1$  is on the left side of the approach road centerline.
- See D1-D10 for approach road plan and profiles.

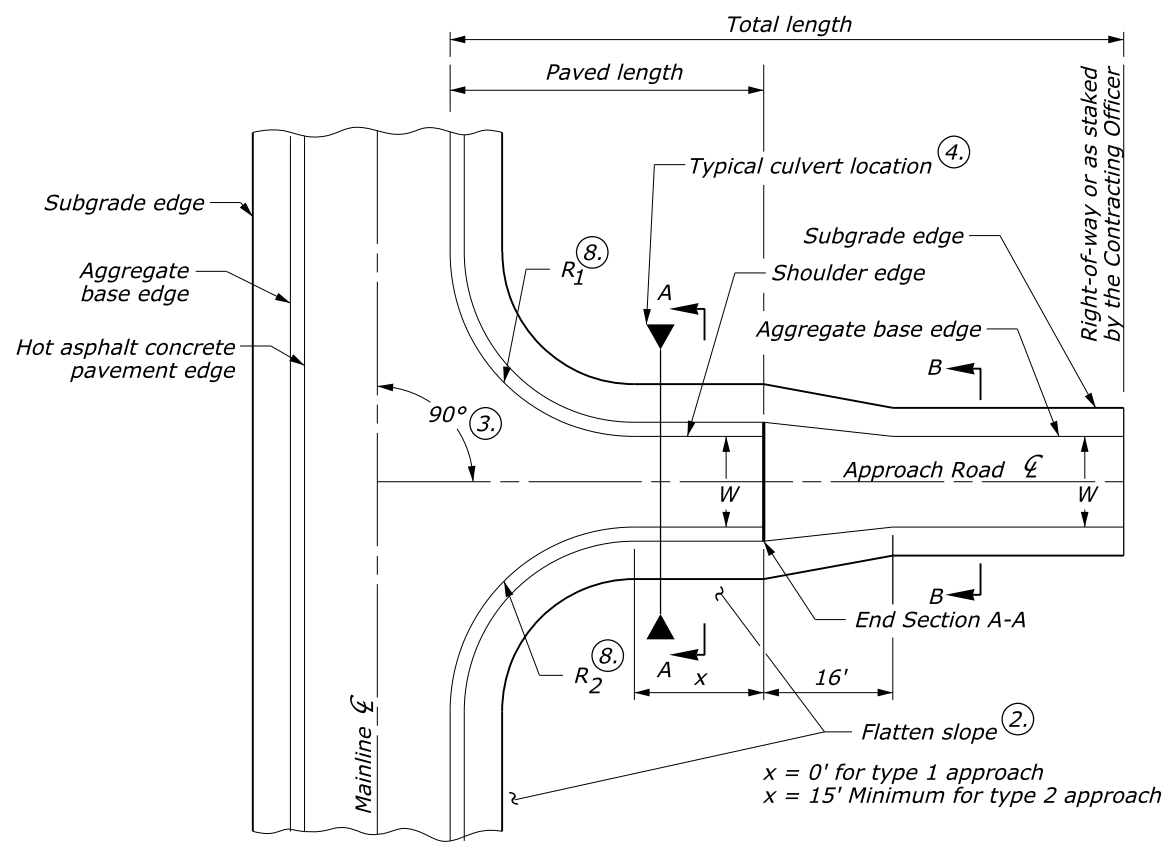

**APPROACH ROAD TYPES 1 & 2 TYPICAL PLAN**

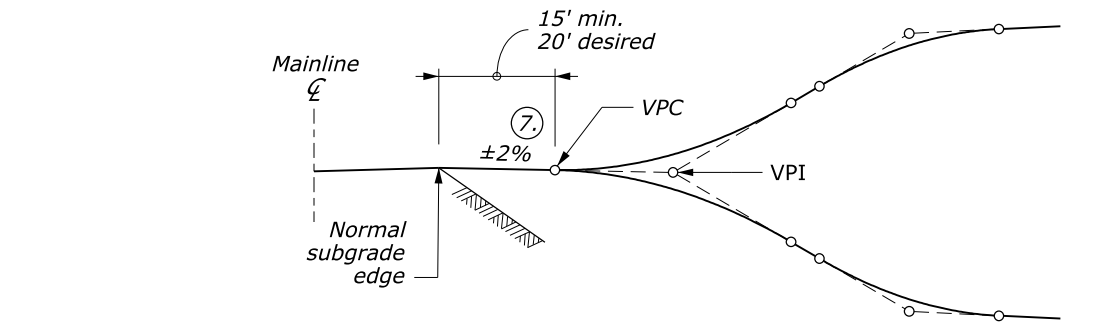

**TYPICAL PROFILE**

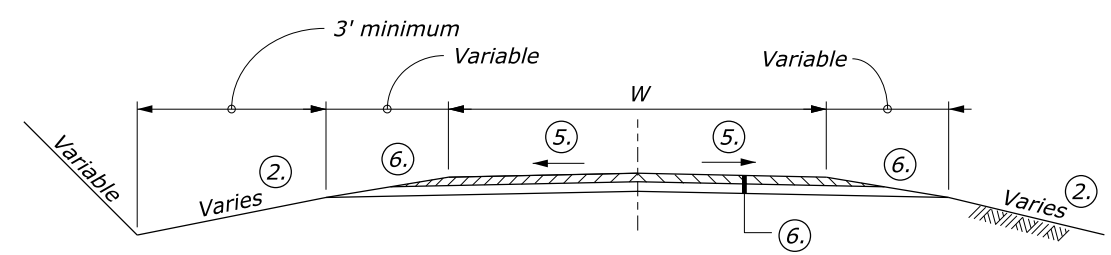

**SECTION A-A**

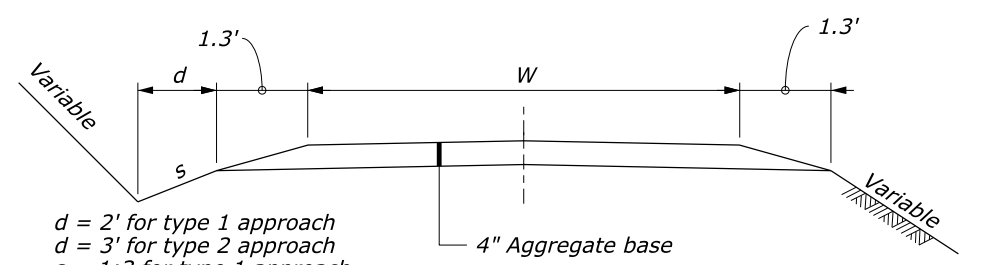

**SECTION B-B**

$d = 2'$  for type 1 approach  
 $d = 3'$  for type 2 approach  
 $s = 1:3$  for type 1 approach  
 $s = 1:4$  for type 2 approach

TYPE	CLASS	MIN. WIDTH W (ft)	MIN. RADIUS R (ft)	SAMPLE APPLICATION
1	A	12	15	Field Access
1	B	14	25	Minimum 1-Way Use
1	C	16	25	Farm Equipment
1	D	16	40	Logging Truck Use
2	A	18	25	Minimum 2-Way Use
2	B	20	25	ADT < 25
2	C	22	40	25 ≤ ADT < 100
2	D	24	40	100 ≤ ADT < 199
2	E	28	50	ADT ≥ 200
3	A	*	N/A	Paved apron

\* Match existing

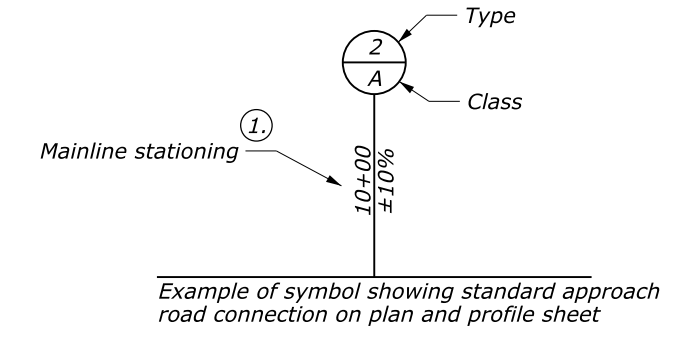

**TYPICAL SYMBOL**

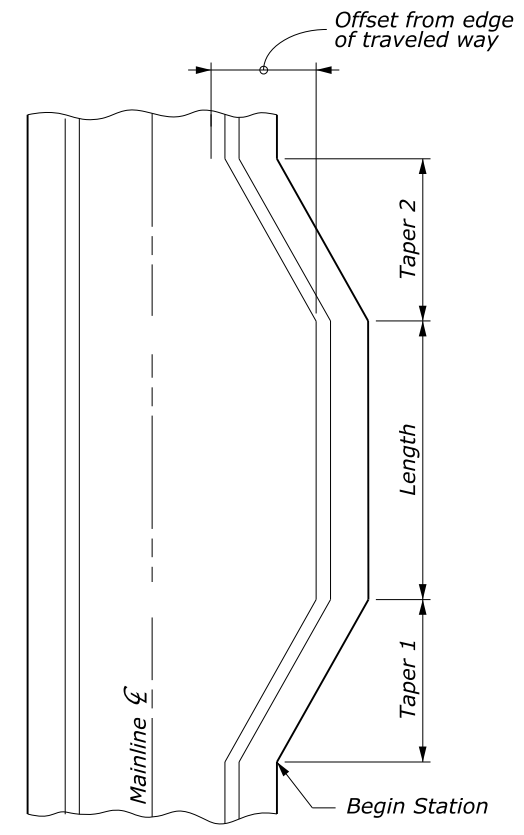

**PULLOUT TYPICAL PLAN**

BEGIN STATION	TAPER 1 (ft)	LENGTH (ft)	TAPER 2 (ft)	OFFSET (ft)
1903+00 Rt.	100	250	50	12
1927+50 Lt.	50	200	50	12
1953+25 Lt.	60	115	60	14
2008+20 Rt.	50	205	50	19
2008+20 Lt.	50	205	50	19

STATION (1)	TYPE & CLASS	PAVED LENGTH (ft)	TOTAL LENGTH (ft)	W (ft)	R1 (ft)	R2 (ft)
1906+19 Rt.	1D	33	111	16	25	25
1911+37 Lt.	1B	33	121	14	25	25
1946+36 Lt.	1B	33	63	14	25	11
1948+20 Rt.	1B	33	301	14	25	11
1960+36 Rt.	1B	33	237	14	18	35
1964+77 Lt.	1B	33	164	14	17	25
1978+75 Rt.	1B	31	91	14	25	25
1982+66 Lt.	1B	33	231	14	10	25
1991+80 Lt.	1B	33	53	14	25	25
1994+86 Rt.	1B	33	131	14	10	50
1995+64 Lt.	1B	33	94	14	25	25
2007+59 Rt.	1B	33	479	14	25	25
2012+09 Lt.	1B	33	195	16	25	25
2025+41 Rt.	1B	33	177	9	9	25
2031+63 Lt.	1B	33	49	30	50	50
2037+56 Lt.	1B	33	284	15	20	25
2049+45 Rt.	1B	33	203	18	25	12
2053+58 Lt.	1B	33	86	15	25	25
2095+81 Rt.	1B	33	106	20	25	25
2097+27 Lt.	1B	33	64	14	12	25

NO SCALE

U.S. DEPARTMENT OF TRANSPORTATION  
 FEDERAL HIGHWAY ADMINISTRATION  
 CENTRAL FEDERAL LANDS HIGHWAY DIVISION

**TYPICAL SECTIONS  
 APPROACH ROADS  
 AND PULLOUTS**



# SUMMARY OF QUANTITIES - Schedule A

REG	STATE	PROJECT	SHEET NO.	TOTAL SHEETS
N/A	CA	FLAP SR 36(13) STATE ROUTE 36	B1	B22

A M E N D	Line Item No.	Pay Item Number	Pay Item Description	Unit	Sheet and Description											Estimated Quantities		Remarks and/or Determination of Estimated Quantity
					B4	B5	B6-B11	B12-B16	B17	B18	B19	B20	B21	B22	Allowance	Bid Schedule		
					Grading Summary	Surfacing Summary	Drainage Summary	Removals Summary	Misc. Summary Sheet 1	Misc. Summary Sheet 2	Misc. Summary Sheet 3	Misc. Summary Sheet 4	Misc. Summary Sheet 5	Misc. Summary Sheet 6	Allowance	Bid Schedule		
	A0050	15101-0000	MOBILIZATION	LPSM													ALL	
	A0100	15206-0000	SLOPE, REFERENCE, AND CLEARING AND GRUBBING STAKE	STA					238.3								238.3	
	A0150	15214-2000	SURVEY AND STAKING, RETAINING WALL	LPSM					All								ALL	
	A0200	15215-3000	SURVEY AND STAKING, DRAINAGE STRUCTURE	EACH			63								2		65	
	A0250	15216-2000	SURVEY AND STAKING, GRADE FINISHING STAKES	STA					476.6								476.6	
	A0300	15301-0000	CONTRACTOR QUALITY CONTROL	LPSM													ALL	
	A0350	15401-0000	CONTRACTOR TESTING	LPSM													ALL	
	A0400	15501-0000	CONSTRUCTION SCHEDULE	LPSM													ALL	
	A0450	15701-0000	SOIL EROSION CONTROL	LPSM													ALL	
	A0500	15705-2200	SOIL EROSION CONTROL, ALTERNATE CHECK DAM (ASPHALT)	LNFT								115			15		130	
	A0550	15802-0000	WATERING FOR DUST CONTROL	LPSM													ALL	
	A0600	20101-0000	CLEARING AND GRUBBING	ACRE					78.5						1.5		80.0	
	A0650	20301-1900	REMOVAL OF PIPE CULVERT	EACH			63								2		65	
	A0700	20304-1000	REMOVAL OF STRUCTURES AND OBSTRUCTIONS	LPSM				All									ALL	
	A0750	20401-0000	ROADWAY EXCAVATION	CUYD	470,986										19,014		490,000	
	A0800	20441-0000	WASTE	CUYD	87,957										4,043		92,000	
	A0850	20703-1000	GEOGRID, UNIAXIAL	SQYD						489,808					15,192		505,000	
	A0900	20703-2000	GEOGRID, BIAxIAL	SQYD						34,199					1,001		35,200	
	A0950	21101-1000	ROADWAY OBLITERATION, METHOD 1	SQYD						22,991					1,009		24,000	
	A1000	25101-2000	PLACED RIPRAP, CLASS 2	CUYD			556								44		600	
	A1050	25101-3000	PLACED RIPRAP, CLASS 3	CUYD			164				21				15		200	
	A1100	25101-4000	PLACED RIPRAP, CLASS 4	CUYD			89								11		100	
	A1150	25201-0000	SPECIAL ROCK EMBANKMENT	CUYD							25,491				509		26,000	
	A1200	25205-0000	ROCK BUTTRESS	CUYD							17,475				525		18,000	
	A1250	25501-1000	MECHANICALLY STABILIZED EARTH WALL, WELDED WIRE FACE	SQFT					24,075						725		24,800	
	A1300	25901-0000	SOIL NAIL	LNFT						23,952	4,563				808		29,323	
	A1350	25902-0000	SOIL NAIL RETAINING WALL	SQYD						2,217					83		2,300	
	A1400	30101-0000	AGGREGATE BASE	TON			41,768								1,732		43,500	
	A1500	30501-0000	AGGREGATE-TOPSOIL COURSE	TON			2,030								70		2,100	
	A1550	40101-5600	SUPERPAVE PAVEMENT, 1/2-INCH OR 3/4-INCH NOMINAL MAXIMUM SIZE AGGREGATE, 0.3 TO <3 MILLION ESAL	TON			26,427								773		27,200	
	A1650	40105-3000	ANTISTRIP ADDITIVE, TYPE 3	TON			264								8		272	
	A1750	40920-1000	FOG SEAL, EMULSIFIED ASPHALT GRADE CSS-1 OR CSS-1H, SS-1 OR SS-1H	TON			33								2		35	
	A1800	41103-0000	PRIME COAT (METHOD 1)	SQYD			79,914								4,086		84,000	
	A1850	41105-0000	BLOTTER	TON													110	As directed by the CO
	A1900	41201-1000	TACK COAT GRADE CSS-1, CSS-1H, SS-1, OR SS-1H	TON			69								1		70	
	A1950	60103-0000	CONCRETE, HEADWALL (6x4 BOX)	EACH			1								1		1	

MileStone: 70% Estimate  
Date Completed: 10/22/14  
Report Date: 10/22/14

# SUMMARY OF QUANTITIES - Schedule A

REG	STATE	PROJECT	SHEET NO.	TOTAL SHEETS
N/A	CA	FLAP SR 36(13) STATE ROUTE 36	B2	B22

A M E N D	Line Item No.	Pay Item Number	Pay Item Description	Unit	Sheet and Description											Estimated Quantities	Remarks and/or Determination of Estimated Quantity	
					B4	B5	B6-B11	B12-B16	B17	B18	B19	B20	B21	B22	Allowance	Bid Schedule		
					Grading Summary	Surfacing Summary	Drainage Summary	Removals Summary	Misc. Summary Sheet 1	Misc. Summary Sheet 2	Misc. Summary Sheet 3	Misc. Summary Sheet 4	Misc. Summary Sheet 5	Misc. Summary Sheet 6	Allowance	Bid Schedule		
	A2000	60103-0140	CONCRETE, HEADWALL FOR 24-INCH PIPE CULVERT	EACH			14										14	
	A2050	60103-0160	CONCRETE, HEADWALL FOR 30-INCH PIPE CULVERT	EACH			1										1	
	A2100	60103-0180	CONCRETE, HEADWALL FOR 36-INCH PIPE CULVERT	EACH			3										3	
	A2150	60103-0220	CONCRETE, HEADWALL FOR 48-INCH PIPE CULVERT	EACH			3										3	
	A2200	60103-0240	CONCRETE, HEADWALL FOR 54-INCH PIPE CULVERT	EACH			1										1	
	A2250	60103-0260	CONCRETE, HEADWALL FOR 60-INCH PIPE CULVERT	EACH			2										2	
	A2300	60103-0420	CONCRETE, HEADWALL FOR 120-INCH PIPE CULVERT	EACH			2										2	
	A2350	60201-0600	18-INCH PIPE CULVERT	LNFT			147									13	160	
	A2400	60201-0800	24-INCH PIPE CULVERT	LNFT			3,849									151	4,000	
	A2450	60201-0900	30-INCH PIPE CULVERT	LNFT			280									10	290	
	A2500	60201-1000	36-INCH PIPE CULVERT	LNFT			528									22	550	
	A2550	60201-1200	48-INCH PIPE CULVERT	LNFT			273									17	290	
	A2600	60201-1300	54-INCH PIPE CULVERT	LNFT			334									16	350	
	A2650	60201-1400	60-INCH PIPE CULVERT	LNFT			142									8	150	
	A2700	60201-2300	120-INCH PIPE CULVERT	LNFT			198									12	210	
	A2750	60210-0600	END SECTION FOR 18-INCH PIPE CULVERT	EACH			6										6	
	A2800	60210-0800	END SECTION FOR 24-INCH PIPE CULVERT	EACH			50										50	
	A2850	60210-0900	END SECTION FOR 30-INCH PIPE CULVERT	EACH			1										1	
	A2900	60210-1000	END SECTION FOR 36-INCH PIPE CULVERT	EACH			5										5	
	A2950	60210-1200	END SECTION FOR 48-INCH PIPE CULVERT	EACH			3										3	
	A3000	60210-1300	END SECTION FOR 54-INCH PIPE CULVERT	EACH			1										1	
	A3050	60210-1400	END SECTION FOR 60-INCH PIPE CULVERT	EACH			1										1	
	A3100	60220-1200	6 FEET SPAN, 4 FEET RISE PRECAST REINFORCED CONCRETE BOX CULVERT	LNFT			139									6	145	
	A3150	60403-0000	INLET	EACH			40										40	
	A3200	60501-0000	STANDARD UNDERDRAIN SYSTEM	LNFT								6,795				305	7,100	
	A3250	60506-0000	UNDERDRAIN SYSTEM (ENCAPSULATED)	LNFT								929				71	1,000	
	A3300	60602-0700	PIPE ANCHOR ASSEMBLY, 24-INCH	EACH			139									1	140	
	A3350	60602-0800	PIPE ANCHOR ASSEMBLY, 30-INCH	EACH			11									4	15	
	A3400	60602-0900	PIPE ANCHOR ASSEMBLY, 36-INCH	EACH			13									2	15	
	A3450	60602-1150	PIPE ANCHOR ASSEMBLY, 54-INCH	EACH			9									1	10	
	A3500	60901-2300	CURB, ASPHALT, 6-INCH DEPTH	LNFT								18,792				608	19,400	
	A3550	60908-1000	PAVED DITCH, ASPHALT	SQYD								6,264				236	6,500	
	A3600	61001-0000	HORIZONTAL DRAIN PIPE	LNFT								16,085				915	17,000	
	A3650	61701-4500	GUARDRAIL SYSTEM MGS, TYPE 2, CLASS A STEEL POSTS	LNFT								4,285				115	4,400	
	A3700	61702-1500	TERMINAL SECTION, TYPE MGS TANGENT	EACH								8					8	
	A3750	61707-4000	STRUCTURE TRANSITION RAILING, MGS SYSTEM	LNFT								50					50	
	A3800	62201-0250	DUMP TRUCK, 10 CUBIC YARD MINIMUM CAPACITY	hour													100	As directed by the CO
	A3850	62201-0550	BACKHOE LOADER, 6 CUBIC FOOT MINIMUM RATED CAPACITY BUCKET, 24-INCH WIDTH	hour													100	As directed by the CO

MileStone: 70% Estimate  
Date Completed: 10/22/14  
Report Date: 10/22/14