

PRELIMINARY ISSUE  
THIS PLAN ISSUED FOR  
ADVANCE INFORMATION ONLY

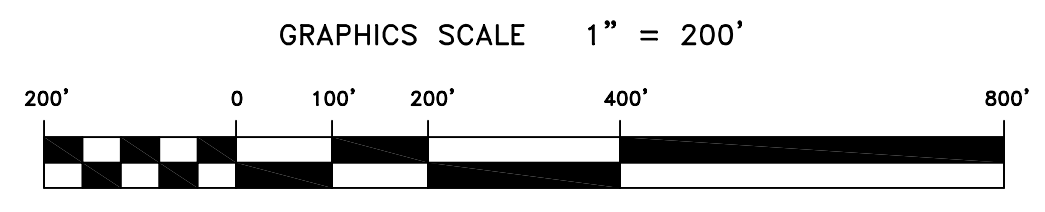
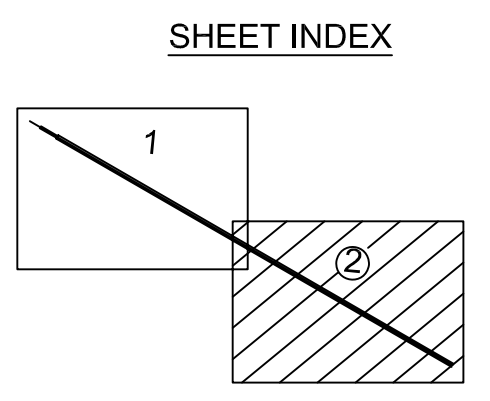

US Army Corps  
of Engineers  
San Francisco District  
1455 Market Street  
San Francisco, CA 94103

Mark	Description	Date	Appr.

SUBMITTED:	M/C	DESIGNED BY:	T/V	CHECKED BY:	E/W
	Hydro Survey Team Leader				
	APPROVAL RECOMMENDED:		DATE:		SHEET NO.
APPROVED:					
Chief, Construction Branch					

PREPARED UNDER THE DIRECTION OF  
CRAIG W. KILEY  
LT. COLONEL, C.E., DISTRICT ENGINEER

CALIFORNIA  
MARIN COUNTY  
SAN RAFAEL CREEK  
ACROSS THE FLAT  
CONDITION SURVEY  
09 JANUARY 2008

Sheet  
reference  
number  
**C2**